

A STRONGER STRUCTURAL CEILING SYSTEM

---

# ISO FLEX-GRID

---



# A SMART AND SIMPLE CONSTRUCTION

---

The Iso Flex-Grid is an engineered structural ceiling system that acts as both a dropped return air ceiling plenum, as well as a support grid, providing a cost effective solution for use in data centres, clean rooms, labs and other environments.

The Iso Flex-Grid system uses high-grade aluminium extrusions with a continuous M10 threaded slot along the entire underside of the grid. The ceiling grid is assembled using 2, 3- and 4-way way high strength diecast connectors.

Because the system has a high load-bearing capacity, no additional attachments are needed through the inner ceiling up to the ceiling above.

Easy to fit ceiling tiles can be supplied in a variety of different materials, sizes, colours and brands. With the ceiling tiles in place you can create a hot return air plenum for use in combination with a contained hot aisle, individual cabinet chimney systems or contained cold aisles. The ceiling tiles can be secured to the grid if preferred.

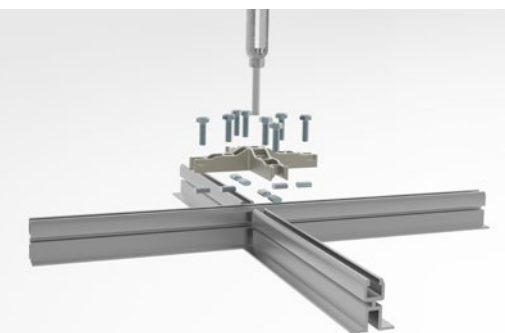

# A STRONG CONSTRUCTION

---

The layout of the ceiling can easily be adapted to row aisles, equipment or other needs by placing the carrier profiles where they are most needed and not according to a predetermined pattern. If it is necessary to make alterations or additions at a later date, Iso Flex-Grid can easily be modified and supplemented according to the new needs.

As standard the Iso Flex-Grid is designed for point loads up to 300 kg.

## Bergvik's Iso Flex-Grid benefits

- Iso Flex-Grid serves the dual purpose of being both a load-bearing grid combined with a drop-down ceiling
- Very low maintenance cost since there is no need for additional suspension points or replacement of ceiling components
- Extremely flexible, allowing for countless overhead suspension points in all directions.
- Does not depend on server rack location or dimensions
- Very cost effective in case of future expansions
- Provide less facility disruptions and ceiling damage when upgrades for equipment changes are done.



---

## CUSTOM MADE SOLUTIONS WITH THE HIGHEST QUALITY

---

Coordinating with Bergvik is worry free. We custom design the floor for every project if needed in our CAD software to provide customers with the quality they expect and deserve. This means that your equipment layout can be decided at the design stage and the floor is designed to adapt around your optimized project design. Additionally, a standard 5-year warranty on the floor is priceless.

Bergvik was founded in 1970. Through all the years, we have exported our floors to more than 100 countries around the world.

Today we design and deliver fully modular and technical floors like Iso Floor, HiFlex Floor, Tech Floor and our proven secure Seismic Bracing Frames. As well as the structural ceiling system - Iso Flex-Grid.

### Our products

ISO FLOOR



Raised floor for data centres and power distribution rooms with unique flexibility.

HIFLEX FLOOR



High-built power distribution floor as an alternative to concrete beams.

SEISMIC BRACING

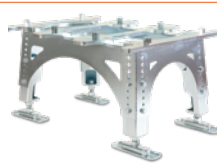

Bergvik's seismically secure raised floor that protects critical electrical equipment.

ISO FLEX-GRID



A load-bearing ceiling system that is both a dropped ceiling and a support grid in one cost effective solution.

TECH FLOOR



An economical standard grid floor system for installation in offices and communication centres.

